

移动数据采集终端 HANDHELD TERMINAL(PDA)

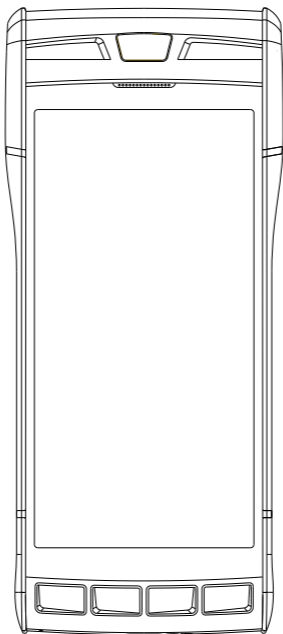

Quick Guide
快速使用指南

概览

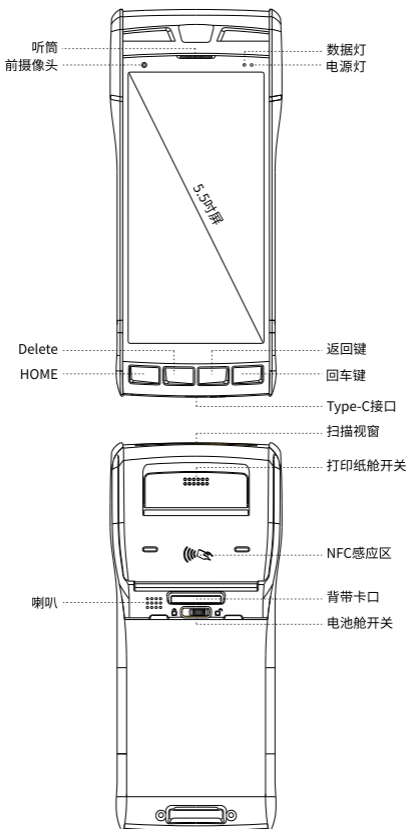

快捷键

截屏操作：同时按住“电源键”+“音量-”

概览

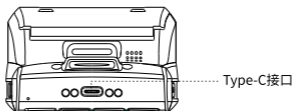
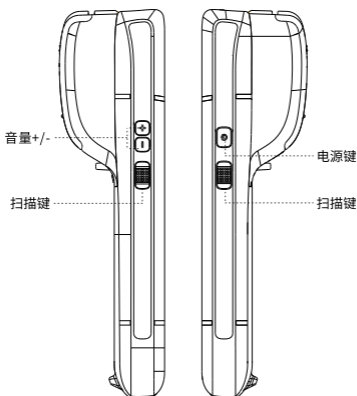
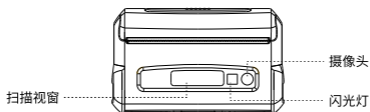

背带安装

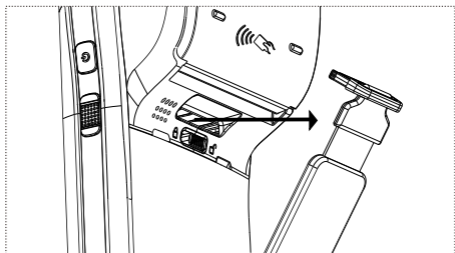
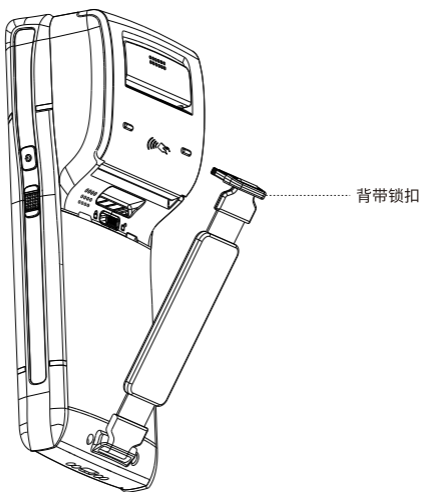

(图一)

按照图一箭头指示方向，手持背带锁扣平行向后拉，打开锁扣。

拆装电池

1. 首先打开背带，然后将电池舱开关拨动至右边。

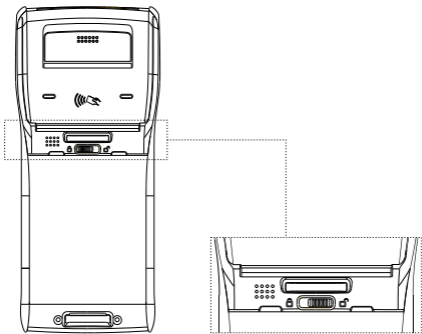

2. 再利用电池舱盖与底壳之间的抓手位打开电池舱盖。

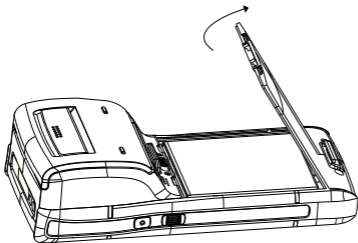

3. 先将电池上端放入到电池舱内部的插孔中，再下压电池底部。

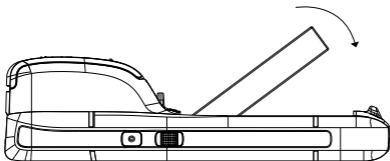

* 收到设备后请先撕开电池正负极绝缘贴,然后再开启设备。

安装TF/SIM卡

1.请按照视图选择相应的的卡槽插入TF / SIM卡。

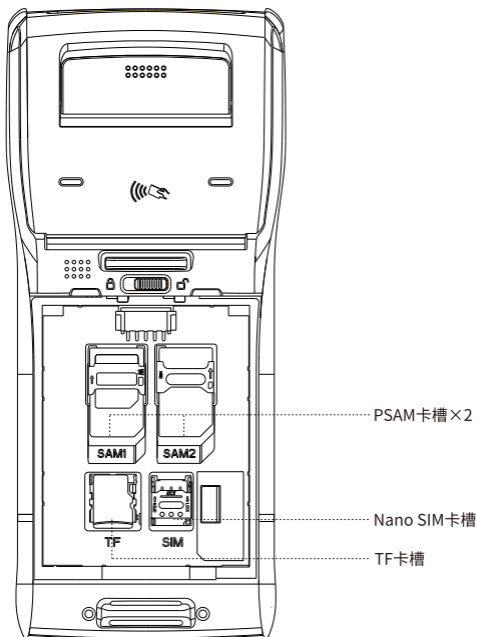

(注意:手持终端机只支持Nano SIM, 标准SIM卡槽是用来安装加密的PSAM卡。)

设备充电

设备有两种充电方式可以选择：

通过设备自带的Type-C USB线，插入Type-C充电口给设备充电。

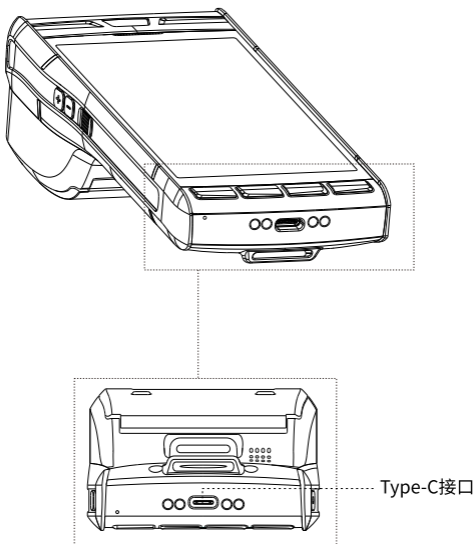

1. 电池充电3-4小时即可充满电，待机时间超过48小时。

* 为防止电池出现过耗状态，请您在设备电量低于20%时为设备电池充电。若电池已经出现过耗保护状态时，请静置设备充电20-30分钟后，设备将会重新显示正常充电。

条码扫描功能(可选)

如果您的设备配有条码扫描功能，请按以下指示操作：

- 1.请在程序列表中找到扫描图标（图一），并打开。
- 2.在（图二）的扫描测试界面，按扫描按键，即可扫描条码。



(图一)



(图二)



(图三)

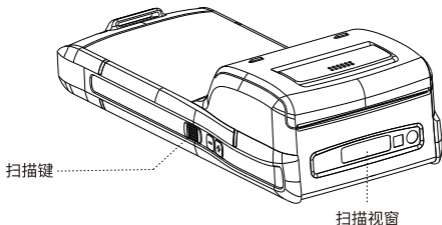

NFC读卡功能

如果您的设备选配有NFC读卡功能，请按以下指示操作：

- 1.请在程序列表中找到NFC图标（图一），并打开；
- 2.在（图二）的读卡测试界面，将卡靠近设备的感应区即可读卡。



(图一)



(图二)

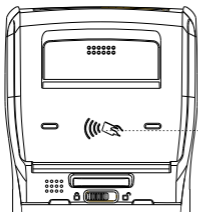

NFC读卡区域

不干胶打印功能

如果您的设备选配有不干胶打印功能，请按以下指示操作：

- 1.请在程序列表中找到不干胶打印图标（图一），并打开；
- 2.在（图二）的打印操作界面，可以进行打印功能的相关测试。



（图一）



（图二）

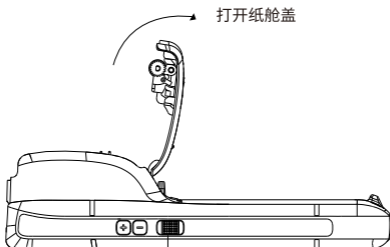

在线升级

我们为您配备了在线升级功能，您可以通过在线升级获得最新最稳定的系统，操作方法如下：

1. 请点击“设置”→“系统”→“关于手机”→“系统更新”；
2. 点击系统更新选项卡，打开（图一）界面；
3. 点击立即检查进行更新。

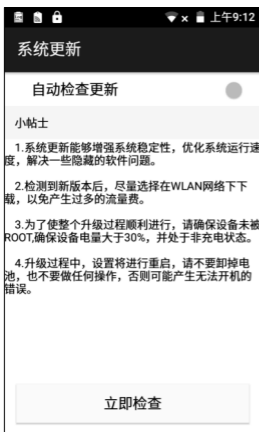

(图一)

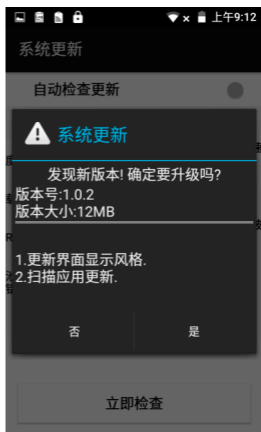

(图二)

常见问题处理

1.机器如何恢复出厂设置？

点击“设置”→“系统”→“重置选项”→“恢复出厂设置”

2.设备不开机怎么办？

(1)新设备不开机请先确认电池是否已经撕掉绝缘贴。

(2)按下电源键需要3-4秒的时间设备屏幕才开始显示，请按电源键开机的时候等待屏幕有显示内容后再松开电源键。

(3)其次排查一下设备电池是否有电，将电池放入到设备内，接上USB数据线，如果屏幕上显示电池充电图标，表示是电池电量不足导致。

3.设备无法充电、无法与电脑无法联机？

如果设备插入电脑的USB接口后,没有任何提示，请更换一个USB接口再测试一下，如果还是没有任何响应。请更换电脑尝试。

4.设备出光了，但是条码却扫描不出来？

这种情况一般是扫描设置的问题，需要进入到扫描设置里面先查看一下键盘输出的选项是否有勾选。如果已经勾选，请复位一下扫描引擎，然后将扫描的开关进行一次关——开的操作。

5.如何排查设备无法扫码？

(1)检查各扫描按键是否能正常使用。

(2)再确认扫描头是否支持该码制条码。

(3)确认扫描镜片无遮挡，条码清晰无遮挡。

(4)扫描设置开关一次并重置确认是否能扫描。

6.如何解决不充电问题？

(1)检查设备适配器以及设备充电口是否良好。

(2)设备长时间未使用请先保持设备充电30分钟，再检查设备充电灯是否亮起。

(3)更换可以正常开机的设备电池，排查确定电池或设备问题。

7.如何正确的使用电池呢？

设备的电池为聚合物电池，电池在没电后请及时充电，不可在空电量或者满电量的情况下长时间存放，最好在50%左右的电量存放，如果长时间不使用设备，请将电池从设备中取出保存。

OVERVIEW

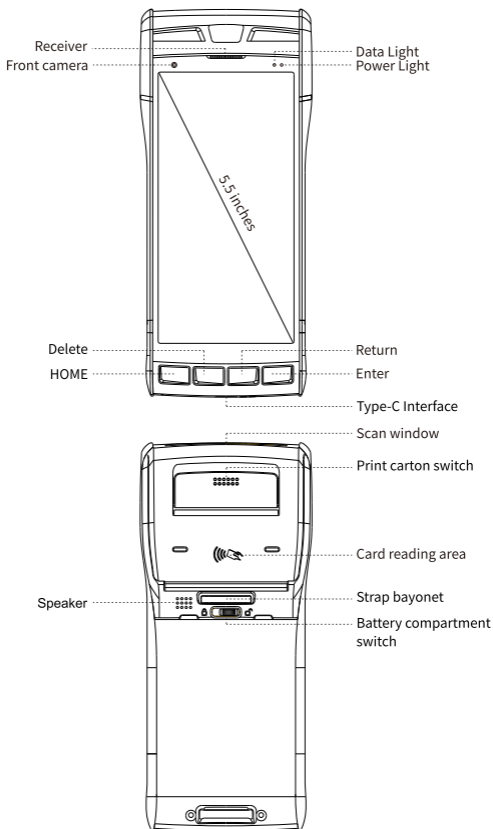

Hot button

Screen capture : "power" + "Volume -"

OVERVIEW

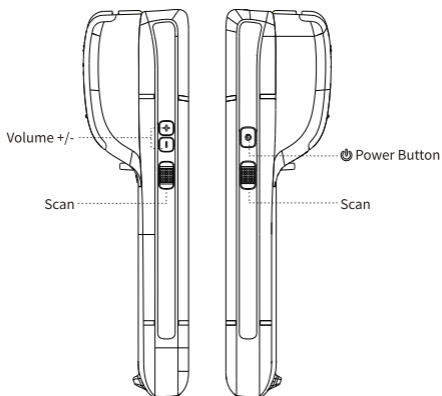
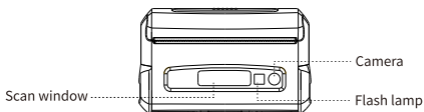

STRAP INSTALLATION

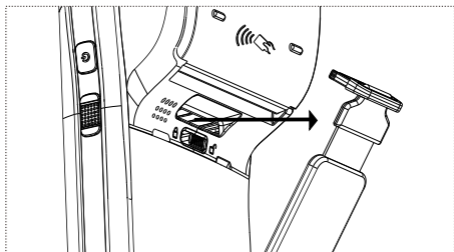
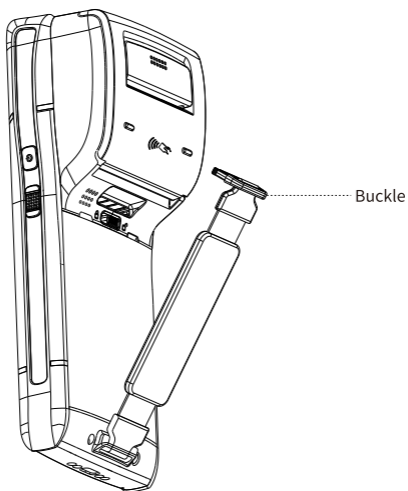

(As Pic 1)

Follow the direction indicated by the arrow sign in Figure 1, pull back the hand strap buckle in parallel to open the buckle.

OPEN THE BATTERY COVER

1. First release the strap and then slide the battery compartment switch to the right.

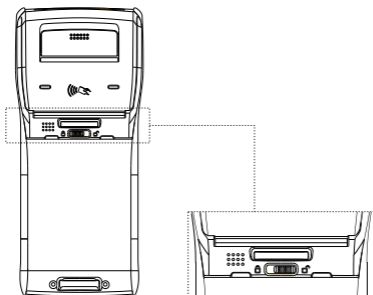

2. Pry and open the battery cover by hand.

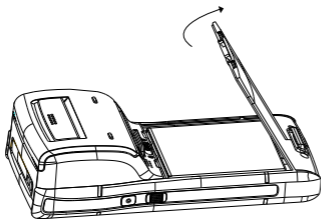

3. Place pins of the upper end of the battery on contact with contact pins on battery compartment, then press down the battery.

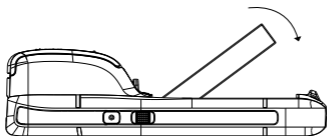

* Please remove the positive and negative insulation yellow sticker on the battery before turning on the device.

INSTALL TF/SIM CARD

1. Pls insert the SIM card into the corresponding slots as shown in the figure below

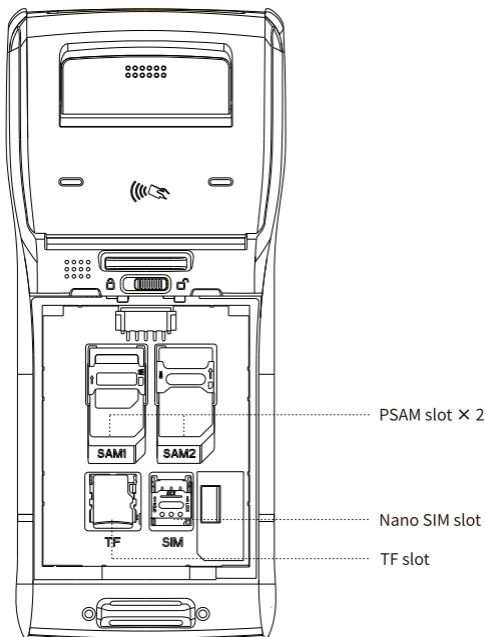

(Warm tips: The handheld terminal is only support Nano SIM card, standard SIM card slot is for PSAM card)

EQUIPMENT CHARGING

DEVICE CHARGING:

Connect the Type-C USB cable to device type-C port to charge.

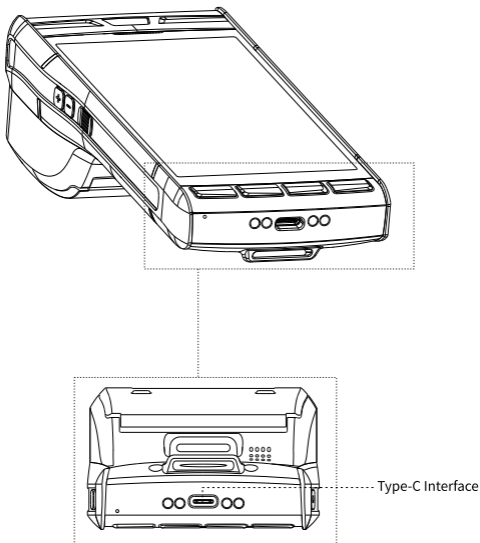

1.The battery can be fully charged after 3-4hours of charging,and the standby time is over 48 hours.

- ★ To prevent the battery from being over-consumed, please charge the device when the battery power is less than 20%.If the battery has been in a over-consumption status, please charge the device for 20-30 minutes. Then it will display a normal charging status.

SCAN (OPTIONAL)

IF YOUR PDA WITH SCAN FUNCTION, PLS OPERATE AS BELOW:

1. Pls find the “scanner” app, and open it. (As Pic 1)
2. In the interface of scan, press scan button to scan the barcode.



(As Pic 1)

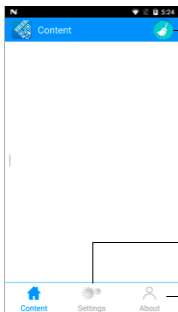

Clear the contents

Settings

About

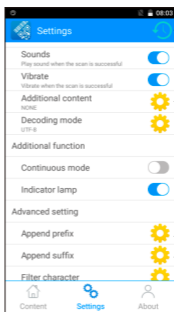

Reset scan

Function setting:
Enter / Tab

Append prefix /
suffix

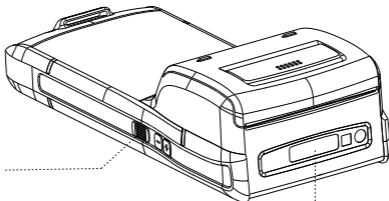

Scan key

Scan window

NFC

IF YOUR PDA WITH NFC FUNCTION, PLS OPERATE AS BELOW:

- 1.Pls find the “NFC” app, and open it.(As Pic 1)
- 2.In the interface of NFC, pls read the card in NFC reading area.



(As Pic 1)

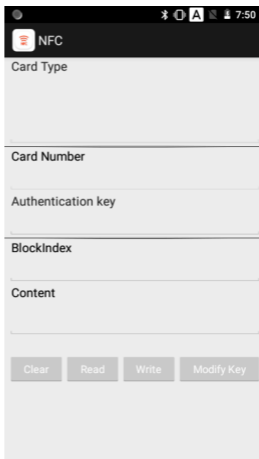

(As Pic 2)

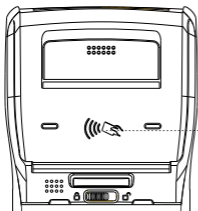

Card reading area

SELF-ADHESIVE PRINTING

IF YOUR DEVICE IS EQUIPPED WITH A PRINTING SELF-ADHESIVE LABEL FUNCTION, PLEASE FOLLOW THE INSTRUCTIONS BELOW:

1. Press sticker Print Demo icon on the screen menu (As Pic1) to enter printer test mode.
2. Press the print icon to test printer operation (As Pic 2).



(As Pic 1)

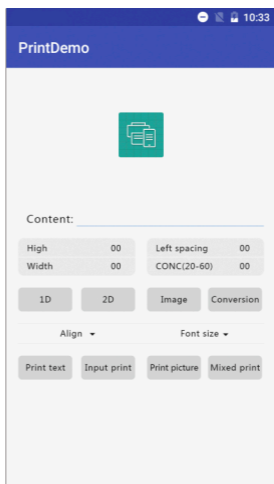

(As Pic 2)

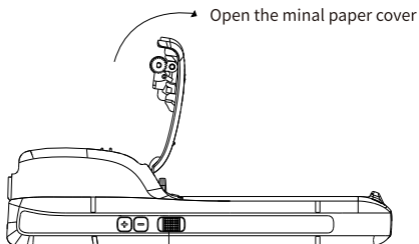

OTA(UPDATE ONLINE)

OUR PDA SUPPORT OTA (UPDATE ONLINE) FUNCTION, YOU CAN UPDATE THE LATEST FIRMWARE BY OTA, OPERATE IT AS BELOW:

- 1.Please click “Setting” → “System” → “About mobile phone” → “System update” ;
- 2.Press “System update” and enter into the updating firmware interface.
- 3.Press “Check now” to update the OS.

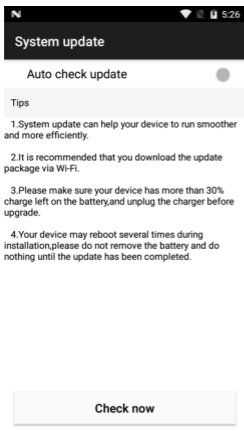

(As Pic 1)

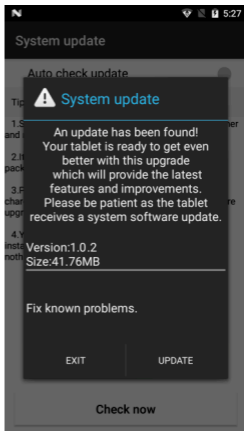

(As Pic 2)

FAQ:

1.How to restore factory settings?

Select “Setting” → “System” → “Reset option” → “Factory date reset”

2.Why can not open the PDA?

(1)If the new device does not turn on,please make sure the sticker on battery has been removed.

(2)Press the power button for 4s until the device screen starts to display and then release the power button.

(3)Pls check if the battery has power,put the battery into PDA and charge it,if the screen shows charging icon,charge the PDA for some time and restart it.

3.PDA can not connect to the PC?

If you connect the PDA with your PC ,no prompt messages,pls change another cable to test,if not work,pls change another pc.

4.When using scanner , there is no data but scan-light on,Why?

(1) Go to scan setting , and check “keyboard output” .

(2) If checked ,then pls reset the scan demo for twice , and operate “OFF” -- “ON” .

5.The device cannot scan the code.

(1) Check if each scan button can be used normally.

(2) Check if the scan engine supports the bar code.

(3) Check if the scanning lens and bar code is clear and unobstructed.

(4) Check the scan setting and reset .

6.The device can not charge.

(1) Check if the device adapter and charging port are good.

(2) If the device is not used for a long time, please keep it charged for 30 minutes. Then check whether the device lights on or not.

(3) Replace the battery of the device that can be turned on normally, check the problem on battery or device.

7.How to use the battery correctly?

The battery is Li-ion battery,If no power , pls immediately charger it, Don's keep the battery with full power or no power for long time,The best way is to keep 50% power of the battery to store it.And if you don't use the PDA for long time,pls pull out the battery from PDA and store it.

致力物联世界，创造智慧生活

COMMITTED TO THE WORLD OF THINGS , CREATING A SMART LIFE